

SINGER

68

USE ONLY **SINGER*** OILS and LUBRICANTS

*They insure freedom from lubricating trouble and
give longer life to sewing equipment*

The following are the correct lubricants for this machine:

TYPE B — MANUFACTURING MACHINE OIL, HEAVY
GRADE

When a stainless oil is desired, use:

TYPE D — MANUFACTURING MACHINE OIL, STAIN-
LESS, HEAVY GRADE

OTHER **SINGER** LUBRICANTS

TYPE E — STAINLESS THREAD LUBRICANT

For lubricating the needle thread of sewing machines for
stitching fabrics or leather where a stainless thread lubri-
cant is required.

TYPE F — MOTOR OIL

For oil lubricated motors and plain bearings in power
tables and transmitters.

NOTE: All of the above oils are available in 1 quart,
1 gallon and 5 gallon cans or in 55 gallon drums.

GEAR LUBRICANT

This specially prepared grease is recommended for gear
lubrication on manufacturing sewing machines.

BALL BEARING LUBRICANT

This pure grease is specially designed for the lubrication
of ball bearings and ball thrust bearings of motors and
electric transmitters, ball bearing hangers of power tables,
etc. **Furnished in 1 lb. and 4 lb. tins.**

7916

INSTRUCTIONS

FOR USING AND ADJUSTING

SINGER* SEWING MACHINES

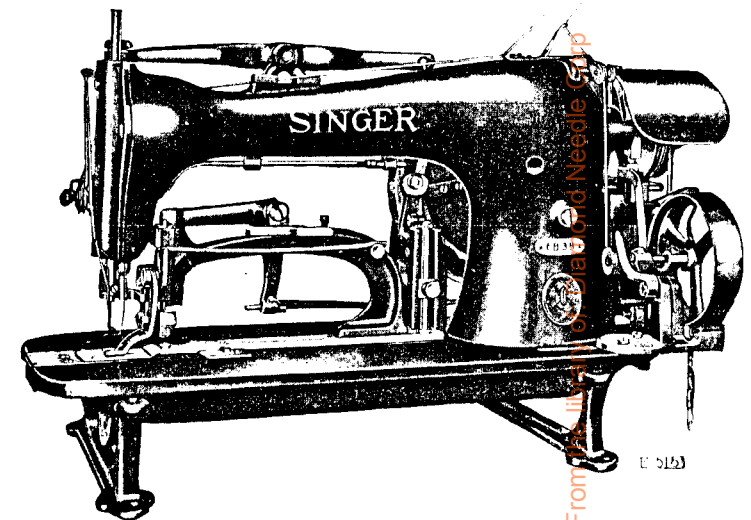

OF

CLASS 68

*A TRADE MARK OF

THE SINGER MANUFACTURING COMPANY

TO ALL WHOM IT MAY CONCERN:

The improper placing or renewal of the Trade-Mark "SINGER" or any other of the Trade-Marks of The Singer Manufacturing Company (all of which are duly Registered Trade-Marks) on any machine that has been repaired, rebuilt, reconditioned, or altered in any way whatsoever outside a SINGER factory or an authorized SINGER agency is forbidden.

THE IMPORTANCE OF USING **SINGER*** PARTS AND NEEDLES IN **SINGER** MACHINES

The successful operation of SINGER machines can only be assured if SINGER parts and needles are used. Supplies are available at all SINGER Shops for the Manufacturing Trade, and mail orders will receive prompt attention.

SINGER Needles should be used
in SINGER Machines.
These Needles and their Containers
are marked with the
Company's Trade-Mark "SIMANCO.*" 1

Needles in Containers marked
"FOR SINGER MACHINES"
are NOT **SINGER** made needles. 2

Copyright, U. S. A., 1914, 1915, 1916, 1926, 1927, 1933 and 1935,
by The Singer Manufacturing Company
All Rights Reserved for All Countries

DESCRIPTION

Machine 68-32 is used for barring the pockets and collars of army overcoats and clothing generally. The machine will accomplish barring in fabrics up to 5/8 inch thickness and is adjustable to make bars varying from 5/16 to 5/8 inch in length. Each bar consists of twelve staying, twenty-seven covering and three tying stitches.

Machine 68-33 makes ornamental tacks which are used to form five point stars for ornamenting naval and other uniforms.

Crow foot or three point tacks are also made for a large variety of work, including the reinforcing and finishing of pockets and ends of seams in military uniforms, men's suits, overcoats, middie blouses, women's skirts, etc. Each tack or point of the star consists of 42 stitches.

Machine 68-38 is intended for barring buttonholes in clothing and is used in connection with Machines of Class 99w. It makes a bar from 1/8 to 1/4 inch long, consisting of seven staying, eleven covering and three tying stitches. It is fitted with a special work clamp which automatically contracts the buttonhole when it is lowered on the work.

Machine 68-39 is used for tacking belt loops on trousers, knickerbockers, etc. It makes tacks from 5/16 to 5/8 inch in length. Each tack consists of twenty-eight stitches, including three tying stitches.

TO SET UP THE MACHINE

Fasten the iron base or the two table brackets, as the case may be, to the table so that when the machine is placed in position, its face plate will be toward the edge of the table nearest the operator and the end of the bed will be about flush with the front edge of the table.

Fasten the table guide to the underside of the table so that the idler pulleys will guide the belt from the driving pulley on the shaft to the pulley on the machine.

Two treadles are sent with each machine, one for operating the clamp and one for starting the machine.

Bore a hole in the table directly under the clamp operating lever **X**, Fig. 21 on the machine for the chain which connects this lever with the treadle for operating the clamp. Hook the chain to the lug nearest the toe edge of the clamp operating treadle.

Bore a second hole in the table directly under the starting lever **C2**, Fig. 21 on the machine for the chain which connects this lever with the treadle for starting the machine.

The chains connecting the treadles with the clamp operating lever and starting lever on the machine should be adjusted to properly operate the clamp and start the machine when the toe edge of each treadle is depressed.

TO OIL THE MACHINE

When the machine is received from the factory, it should be thoroughly cleaned and oiled.

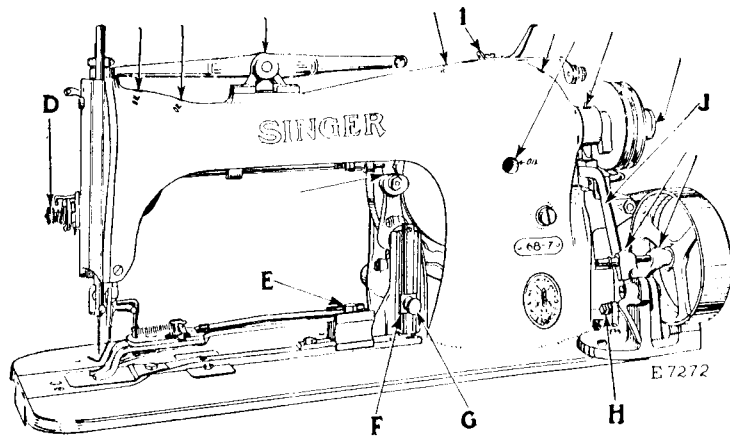

Fig. 2. Oiling Points at the Right of the Machine
Also Adjustments on the Machine

Oil should be applied to all oil holes and at all places designated by arrows in Figs. 2, 3, 20 and 21, and at all places where there are parts in movable contact. When the machine is in continuous use, it should be oiled at least twice each day. The loose pulley at the end of the machine must be oiled frequently through the hole in the center of the large screw head at the end of the shaft.

The shuttle bearing in the shuttle race should be oiled each time a bobbin is replaced.

Use "TYPE B" or "TYPE D" OIL, sold only by Singer Sewing Machine Company. For description of these oils, see inside front cover.

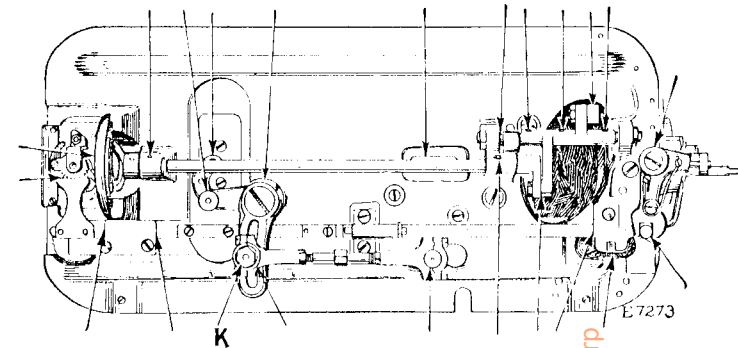

Fig. 3. Oiling Points in the Base of the Machine
Also Adjustment (K) for Regulating Throw
of Button Clamp Across the Machine

SPEED

The maximum speed recommended for Machines of Class 68 is 1000 stitches per minute.

NEEDLES

Needles for Machines of Class 68- are of the Class and Variety numbers listed below:

Machines	Class and Variety	Sizes
68-32	68 x 13	16, 18, 19
68-33	68 x 5	11, 14, 16, 17, 18, 19, 21
68-38	68 x 7 for light goods	14, 16, 18, 19
	68 x 5 for heavy goods or leather	11, 14, 16, 17, 18, 19, 21
68-39	68 x 5	11, 14, 16, 17, 18, 19, 21

The size of the needle to be used should be determined by the size of the thread, which must pass freely through the eye of the needle. The use of rough or uneven thread, or thread which passes with difficulty through the eye of the needle, will interfere with the successful use of the machine.

Orders for needles must specify the **quantity** required, the **size**, also the **class** and **variety** numbers, separated by the letter x.

The following is an example of an intelligible order:

"100 No. 16, 68 x 5 Needles."

The best results will be obtained when using the needles sold by Singer Sewing Machine Company.

THREAD

Left twist thread should be used in the needle. Either right or left twist thread can be used for the bobbin.

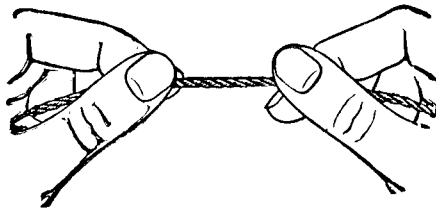

Fig. 4. How to Determine the Twist

Hold the thread as shown above. Turn the thread over toward you between the thumb and forefinger of the right hand; if left twist, the strands will wind tighter; if right twist, the strands will unwind.

TO SET THE NEEDLE

Loosen the set screw in the lower end of the needle bar and put the needle up into the bar as far as it will go, with the long groove of the needle toward the front of the machine and its eye directly in line with the bed of the machine; then tighten the set screw.

TO REMOVE THE BOBBIN

Reach under the bed of the machine with the left hand and open the shuttle, pulling the hinged portion toward you, then remove the bobbin (see Fig. 7, page 8).

TO REMOVE THE BOBBIN FROM MACHINE 68-32

Reach under the bed of the machine with the left hand and open the bobbin case latch and lift out the bobbin case. While the latch remains open, the bobbin is retained in the bobbin case. Release the latch, turn the open end of the bobbin case downwardly and the bobbin will drop out.

TO WIND THE BOBBIN

Place the bobbin winder on the machine as shown in Fig. 5 and fasten it securely to the bed of the machine by the two screws.

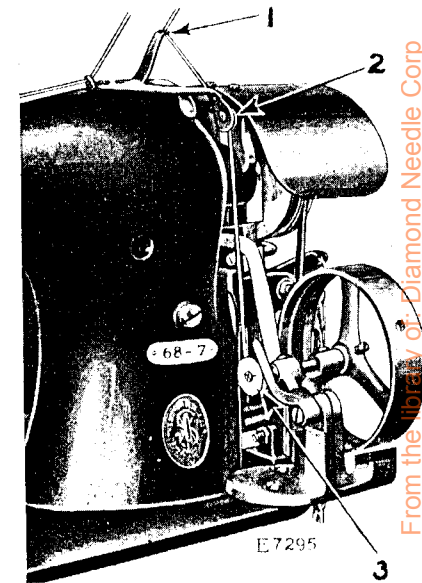

Fig. 5. Winding the Bobbin

Place the bobbin on the bobbin winder spindle and push it up closely against the shoulder, having the small pin in the shoulder enter the slot in the bobbin. Pass the thread from the thread unwinder down through the thread guide 1, Fig. 5 at the top of the machine and between the discs 2, Fig. 5 on the tension bracket, then wind the end of the thread around the bobbin 3, Fig. 5 a few times, and push the bobbin winder driving pulley over against the machine belt. When sufficient thread has been wound upon the bobbin, the bobbin winder will stop automatically. Bobbins can be wound while the machine is stitching.

TO THREAD THE SHUTTLE

(Except Machine 68-32)

Hold the bobbin between the thumb and forefinger of the left hand, the thread drawing on top from the right toward the left (see Fig. 6),

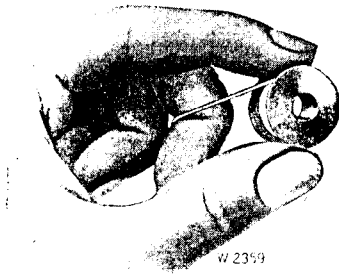

Fig. 6. Showing Direction of Thread on Bobbin

and place it into the shuttle cap as shown in Fig. 7. When the thread is drawn from the bobbin, the bobbin should turn over toward the left.

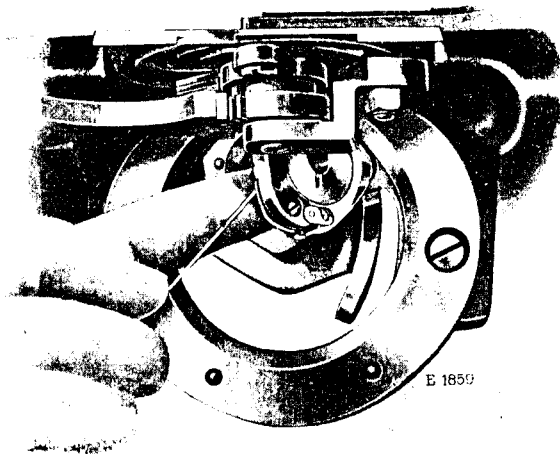

Fig. 7. Replacing the Bobbin

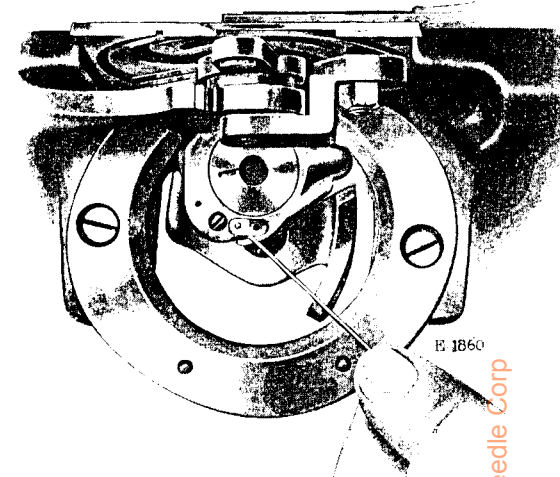

Fig. 8. Threading the Shuttle

Close the cap and draw the thread into the slot in the edge of the cap, as shown in Fig. 8, then into the delivery eye of the shuttle (see Fig. 9). Allow about three inches of thread to hang free from the shuttle.

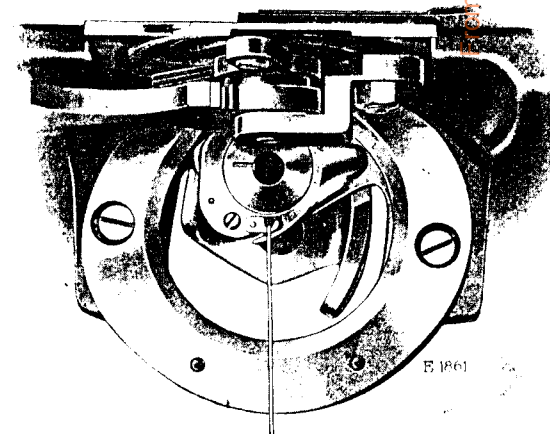

Fig. 9. Shuttle Threaded

in the Library of: Diamond Needle Corp

TO THREAD THE BOBBIN CASE FOR MACHINE 68-32

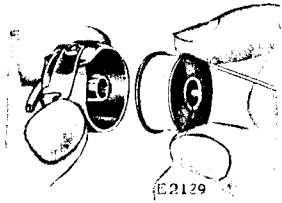

Fig. 10

With the left hand hold the bobbin case as shown in Fig. 11, the slot in the edge being near the top, and place the bobbin into it.



Fig. 11

Then pull the thread into the slot in the edge of the bobbin case as shown in Fig. 11; draw the thread under the tension spring and into the delivery eye at the end of the tension spring. (See Fig. 12).



Fig. 12

TO REPLACE THE BOBBIN CASE IN MACHINE 68-32

After threading, take the bobbin case by the latch and place it on the center stud of the bobbin case holder, release the latch and press the bobbin case back until the latch catches the groove near the end of the stud and the positioning finger enters the slot at the top of the shuttle race. Allow about two inches of thread to hang free with which to commence sewing.

TO THREAD THE NEEDLE

(See Fig. 13)

Pass the thread from the unwinder, down through the thread guide 1, Fig. 2 at the top of the machine, through the thread eyelet 2, Fig. 13

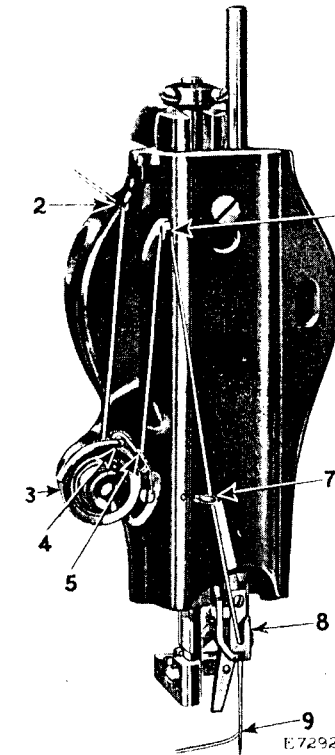

Fig. 13. Threading the Needle

in the upper end of the face plate, down under from left to right between the tension discs 3 at the front of the face plate, over the wire guide 4 above the tension discs, into the hook 5 of the thread take-up spring, up and from left to right through the eye 6 in the end of the thread take-up lever, down through the wire thread guide 7 at the front of the face plate, into the thread nipper 8 near the lower end of the needle bar, down and from front to back or from the long groove side through the eye 9 of the needle. Draw about two inches of thread through the eye of the needle with which to commence sewing.

TENSIONS

The needle and bobbin threads should be locked in the center of the thickness of the material, thus:



Fig. 14. Perfect Stitch

If the tension on the needle thread is too tight, or if that on the bobbin thread is too loose, the needle thread will lie straight along the upper surface of the material, thus:



Fig. 15. Tight Needle Thread Tension

If the tension on the bobbin thread is too tight, or if that on the needle thread is too loose, the thread will lie straight along the underside of the material, thus:



Fig. 16. Loose Needle Thread Tension

TO REGULATE THE TENSIONS

The tension on the needle thread is regulated by the thumb nut **D**, Fig. 2 at the front of the face plate. To increase the tension, turn the thumb nut over to the right. To decrease the tension, turn the thumb nut over to the left.

The tension on the bobbin thread is regulated by the screw near the delivery eye on the outside of the shuttle (except for Machine 68-32). To increase the tension, turn this screw over to the right. To decrease the tension, turn this screw to the left.

When the tension on the bobbin thread has been once properly adjusted, it is seldom necessary to change it as a correct stitch can usually be obtained by varying the tension on the needle thread.

TO REGULATE THE TENSION ON THE BOBBIN THREAD FOR MACHINE 68-32

The tension on the bobbin thread is regulated by the larger screw **1**, Fig. 11 in the tension spring on the outside of the bobbin case. To increase the tension, turn this screw over to the right. To decrease the tension, turn the screw over to the left.

TO OPERATE THE HAND STOP LEVER ON MACHINE 68-32

The purpose of the hand stop lever **L2**, Fig. 17 is to enable the operator to instantly stop the machine in case the thread breaks during the

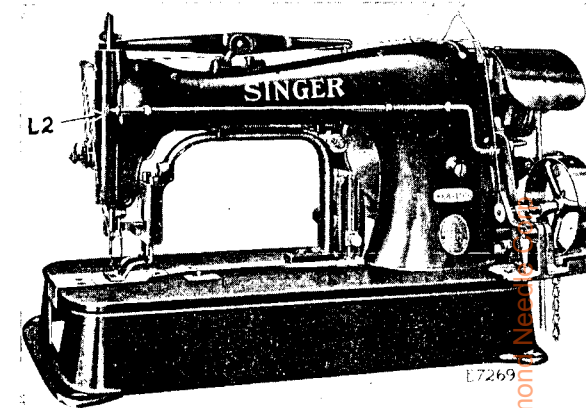

Fig. 17. Showing Machine with Hand Stop Lever

stitching operation. When the hand stop lever **L2** is pushed backwardly, it causes the trip lever to release the stop cam interlocking rod case, thus shifting the belt to the loose pulley and stopping the machine. When the machine is re-threaded, the stitching operation can be resumed at the point where the machine was stopped and the machine will then continue to its regular stopping position.

TO ADJUST THE MACHINE FOR SEWING ON TWO HOLE OR FOUR HOLE OR BAR BUTTONS

To adjust the machine for sewing on two hole or bar buttons, loosen the thumb screw **G**, Fig. 2 in the sliding block **F**, Fig. 2 in the upright slot at the extreme rear of the clamp arm and move the sliding block up to the highest point in the slot, then tighten the thumb screw. The throw of the clamp across the bed of the machine should be adjusted, as instructed on the following page, so as to bring the needle in the center of each of the holes in the button.

To sew on four hole buttons, it will be necessary to adjust the throw of the clamp across the bed of the machine and lengthwise of the bed of the machine, according to the distance between the holes of the button to be sewn on.

TO REGULATE THE THROW OF THE BUTTON CLAMP LENGTHWISE OF THE MACHINE

The throw or amount of travel of the button clamp lengthwise of the bed of the machine is regulated by means of the sliding block **F**, **Fig. 2** which is fastened in position by the thumb screw **G**, **Fig. 2** in the upright slot of the feed regulator. To increase the throw or movement of the button clamp lengthwise of the bed of the machine, loosen the thumb screw **G** and move the sliding block **F** downwardly. To decrease the throw or movement of the clamp, move the sliding block **F** upwardly. When the sliding block is in its highest position in the slot, there will be no movement of the clamp lengthwise of the bed of the machine. Care should be taken to see that when the needle descends, it will enter the center of the holes in the button. When the desired throw or movement of the clamp has been obtained, tighten the thumb screw **G**.

TO REGULATE THE THROW OF THE BUTTON CLAMP ACROSS THE MACHINE

The throw or amount of travel of the button clamp across the bed of the machine is regulated by means of the movable stud which is fastened into position by the hexagon nut **K**, **Fig. 3** at the left and under the bed of the machine. To increase the throw of the clamp across the bed of the machine, loosen the hexagon nut **K** and move the stud to the right in the slot. To decrease the throw of the clamp, move the stud to the left in the slot. Care should be taken to see that when the needle descends, it will enter the center of the holes in the button. When the desired throw of the clamp has been obtained, tighten the hexagon nut **K**.

TO MAKE THE STAR OR FIVE POINT TACK ON MACHINE 68-33

One side of the clamp indicator plate **D3**, **Fig. 18** is marked with five notches for making the star or five point tack. Remove the five screws

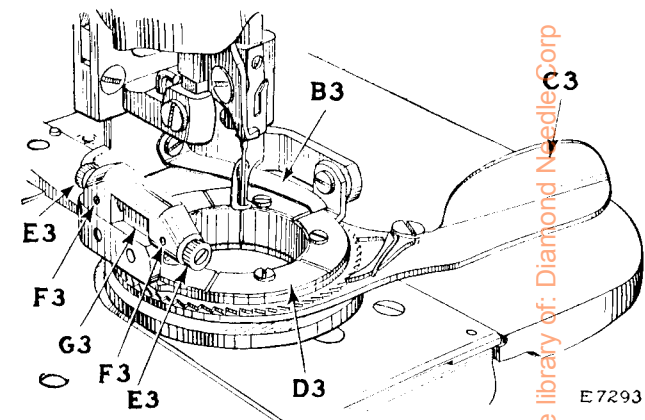

Fig. 18. Adjustments on Clamp of Machine 68-33

which fasten the indicator plate **D3** in position, and set the plate so that the side with the five notches marked upon it is at the top. Turn the ratchet lever **C3**, **Fig. 18** until the indicator finger **B3**, **Fig. 18** engages one of the notches, then proceed to make the first tack. For the next tack, turn the ratchet lever until the indicator finger enters the next notch and repeat the process until the star or five point tack is finished.

TO MAKE THE CROW FOOT OR THREE POINT TACK ON MACHINE 68-33

One side of the clamp indicator plate **D3, Fig. 18** is marked with three notches for making the crow foot or three point tack. Remove the five screws which fasten the indicator plate **D3** in position, and set the plate so that the side with the three notches marked upon it is at the top. Turn the ratchet lever **C3, Fig. 18** until the indicator finger **B3, Fig. 18** engages one of the notches, then proceed to make the first tack. For the next tack, turn the ratchet lever until the indicator finger enters the next notch and repeat the process until the crow foot or three point tack is finished.

TO ADJUST THE CLAMP RING LEVELING STUDS ON MACHINE 68-33

The purpose of the clamp ring leveling studs is to keep the clamp ring parallel with the feed plate.

If the clamp ring is not parallel with the feed plate, loosen the two small set screws **F3, Fig. 18** and turn the two stud spring screws **E3, Fig. 18** until the clamp ring is parallel with the feed plate. The two studs **E3** should very lightly touch the upright part of the clamp ring holder **G3, Fig. 18**.

NOTICE TO OPERATOR

NEVER REST FOOT ON STARTING TREADLE. As soon as machine is "tripped" this treadle must be completely released in order to operate efficiently. Failure to observe this caution may result in severe damage to machine.

TO OPERATE MACHINE 68-38

Place the work in the machine with the purl side of the buttonhole up, inserting the eyelet end of the buttonhole into the machine first and at

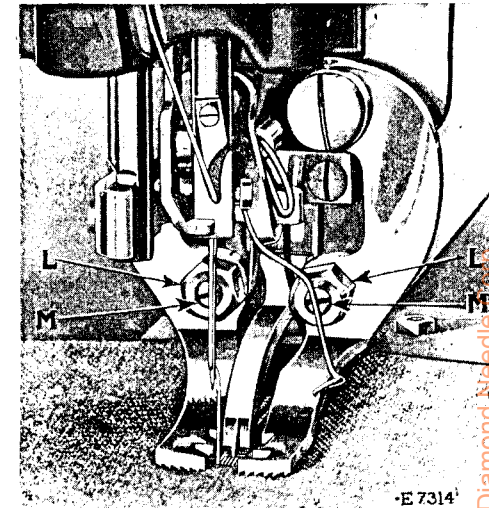

Fig. 19. Showing How the Bar is Located at the End of Buttonhole

the same time drawing the thrum ends of the thread and cord tightly toward you. Push the end of the buttonhole to be barred as far as the fin will permit, as shown in **Fig. 19**, having the fin enter centrally in the slit of the buttonhole, then lower the clamp on the work, holding the goods firmly while the clamp is descending. This will accurately locate the bar at the end of the buttonhole. Then start the machine. When the machine stops, remove the work and cut the thrums or loose ends of the cord and thread close to the bar, so as to leave a cleanly finished buttonhole.

As the clamp feet automatically move inwardly when they are lowered on the work, they draw in the material, thus contracting the buttonhole, so that the cut edges of the buttonhole lie close together when the barring operation is completed.

The amount of gather of the fabric by the clamp feet should be regulated according to the material which is being sewn. For example, loosely woven or stretchy materials will require less gathering than closely woven materials.

To regulate the amount of gather of the goods, loosen the two lock nuts **L, Fig. 19** and turn the two adjusting screws **M, Fig. 19** to the right or left, as may be required, then securely tighten the two lock nuts **L**. Care must be taken to see that the clamp feet are equally spaced on each side of the fin.

INSTRUCTIONS
FOR
ADJUSTERS AND MECHANICS

TO SET THE NEEDLE BAR AT THE CORRECT HEIGHT

Turn the tight pulley over to the right until the needle bar is at its highest point. Remove the work clamp and the feed plate. Take out the

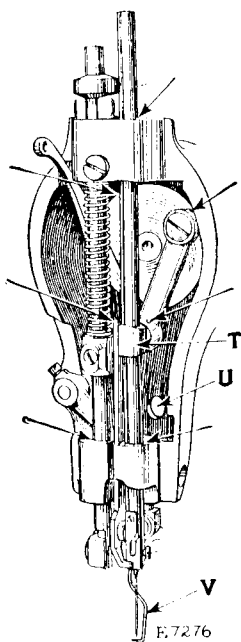

Fig. 20

two screws which hold the throat plate in position, and remove the throat plate by lifting and drawing it toward the front. This will give a clear view of the point of the shuttle for the purpose of timing.

The needle bar should be set so that when it is at its lowest point, the point of the shuttle will be about $9/64$ inch to the left of the center of

the needle. When the point of the shuttle is at the center of the needle on the upward stroke of the needle bar, the top of the eye of the needle should be about $1/16$ inch below the point of the shuttle.

If the needle bar is not set at the correct height, loosen the clamping screw in the needle bar connecting stud **T**, Fig. 20. (This screw can be reached through the hole **U**, Fig. 20 provided for the purpose in the arm). After loosening the screw, raise or lower the needle bar as may be required, then securely tighten the screw in the needle bar connecting stud **T**.

TO REMOVE AND REPLACE THE SHUTTLE RACE

Turn the tight pulley over to the right until the needle bar is at its highest point. Take out the two screws which fasten the shuttle race to the machine and remove the shuttle race. Then remove the shuttle from the shuttle race.

When replacing the shuttle race, have the needle bar at its highest point, and position the shuttle in the race so that it correctly engages the shuttle driver, then securely fasten the shuttle race in position by means of the two screws.

FEED CAMS

Following is a list of the feed cams used in Machines of Class 68-, showing the number of stitches and number of stops made by each cam during one complete revolution, also the number of stitches in each group:

Machine No.	Feed Cam No.	No. of Stitches per Revolution	No. of Stops per Revolution	No. of Stitches in Each Group
68-32	18407	42	1	42
68-33	17783	42	1	42
68-38	17791	42	2	21
68-39	17791	42	2	21

TO REMOVE AND REPLACE THE FEED CAM

The feed cam **E2**, **Fig. 21** is cut to make the number of stitches specified in the list on the preceding page, and to stop the machine automatically when these stitches are completed.

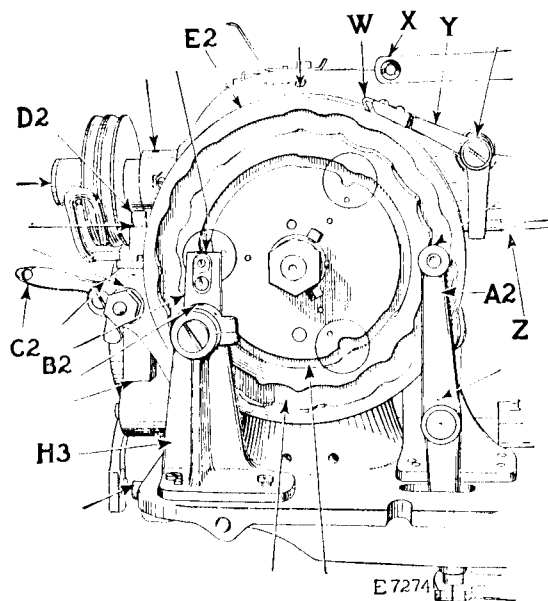

Fig. 21

The feed cam has two cam grooves in its outer face, one of these being for the roller on the feed across lever **A2**, **Fig. 21** and the other for the roller for the thread cutter lever **B2**, **Fig. 21**. Depressions are made in the edge of the feed cam for operating the nipper lever **Y**, **Fig. 21**.

To remove the feed cam **E2** from its shaft, drive out the position pin and loosen the two set screws and remove the nut which holds the feed cam on its shaft. Remove the thread cutting lever bracket **H3**, **Fig. 21** and the feed across lever **A2**, **Fig. 21**, then slide the feed cam off its shaft. Before replacing the feed cam on its shaft, see that the machine is set in the exact position at which it stops automatically, that is, the interlocking rod **D2**, **Fig. 21** at the rear of the machine must be engaged with the notch in the stop cam. Then place the feed cam on its shaft, replace the thread cutting lever **B2** and feed across lever **A2**, and turn the feed cam so that the nipper lever extension **W**, **Fig. 21** is in the exact position it occupies when the machine is stopped automatically, or so that the end of the nipper lever extension **W** will just drop into the

first of the two depressions in the edge of the feed cam, but will not be raised, in the least, by the overthrow of the cam, then fasten the cam securely in position on its shaft by means of the position pin, two set screws and nut. Also securely fasten the thread cutting lever bracket **H3** and feed across lever **A2** in position.

A feed cam made for a specified number of stitches cannot be used with a driving worm and worm wheel designed for a different number of stitches; nor is it advisable to attempt to change a machine so as to make a different number of stitches at each complete revolution of the feed cam, except at the factory.

TO ADJUST THE AUTOMATIC NEEDLE BAR THREAD NIPPER

The purpose of the automatic needle bar thread nipper **8**, **Fig. 13** is to hold the needle thread during the first descent of the needle until the needle reaches the goods, then release the needle thread so as to allow it to pass freely down the side of the needle. When the needle is on its upward stroke, the nipper again holds the needle thread, which is drawn back by the upward motion of the needle bar, and again released by the nipper to allow the thread take-up lever to take up the balance of the thread which has passed around the shuttle. When the machine is automatically stopped, the nipper again holds the needle thread to prevent it from being withdrawn from the needle by the action of the thread take-up spring.

The above description of the action of the nipper applies to Machines of Class 68 fitted with feed cams which have two depressions for the nipper lever at each stopping place in the edge of the cam, and a raised portion between the depressions. On machines of Class 68, fitted with feed cams, which have only one depression for the nipper lever at each stopping place in the edge of the cam, the needle thread is held by the nipper only during the first descent of the needle and again when the machine automatically stops.

The nipper can be adjusted to nip the thread more or less by changing the length of the nipper rod by means of the stud and nut at **Z**, **Fig. 21** on the rod near the nipper driving lever.

The nipper can be timed to nip the thread earlier or later by loosening the two screws which hold the nipper driving lever extension **W**, **Fig. 21** in position and moving the extension forward or backward, as required, after which securely tighten the two screws.

THREAD WIPER

The thread wiper wire **V**, **Fig. 20** must stand at the right of the needle while sewing; it moves over to the left when the clamp is raised, drawing the end of the needle thread out of the goods and returns to its normal position when the clamp is lowered.

TO ADJUST THE THREAD TAKE-UP SPRING

The thread take-up spring **F2**, **Fig. 22** should be set so that when the eye of the needle reaches the goods on the downward stroke of the

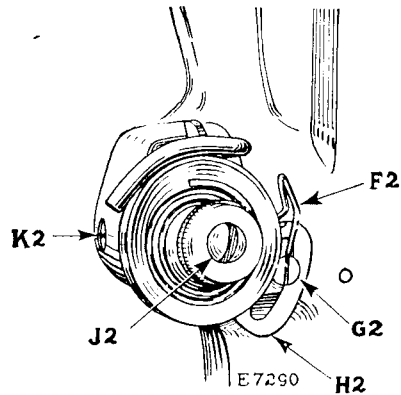

Fig. 22. Adjustment of Thread Take-up Spring

needle bar, the spring will be through acting and will rest against the thread take-up spring regulator plate **H2**, **Fig. 22**. If the thread take-up spring is not correctly set, loosen the set screw **G2**, **Fig. 22** which holds the thread take-up spring regulator plate **H2** in position and lower the plate **H2** for more movement of the spring, or raise it for less movement. When the spring is correctly set, securely tighten the set screw **G2**.

The tension on the thread take-up spring **F2** is regulated by loosening the set screw **K2**, **Fig. 22** at the side of the face plate and turning the tension stud **J2**, **Fig. 22** over toward you to increase the tension, or over from you to decrease the tension. When the desired tension is obtained, securely tighten the set screw **K2**.

The tension on the thread take-up spring should be just sufficient to take up the slack of the needle thread until the eye of the needle reaches the goods in its descent.

THE THREAD CUTTING MECHANISM

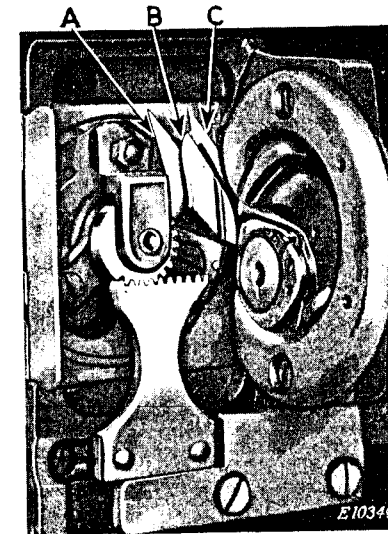

Fig. 23

Fig. 23 shows the position of the thread cutting knives **A** and **B**, and the barbed spring **C**, at the instant of cutting the threads; **A** is the shuttle thread knife and **B** the needle thread knife; there is an immediate slight retraction from this cutting position owing to the recovery by the parts from the overthrow which causes the knives to cut the threads.

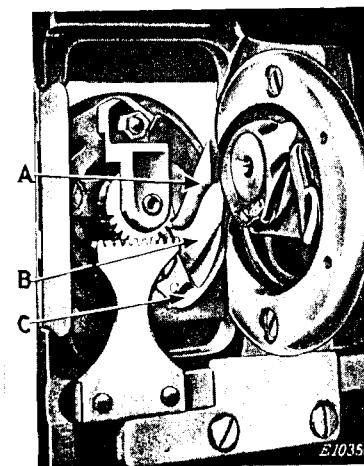

Fig. 24

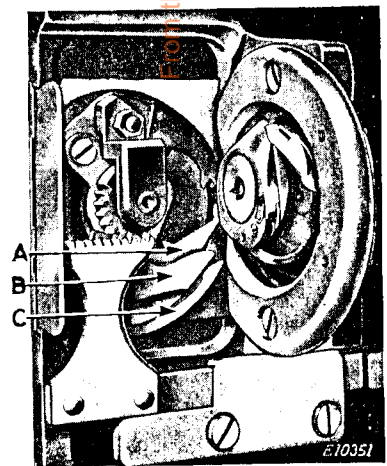

Fig. 25

After the first puncture of the goods by the needle, the knives are retracted to the position shown in **Fig. 24**.

Part of the thread drawn by the shuttle beneath the throat plate must pass under the end of the barbed holding spring **C**, which should lie flat against the under side of the throat plate so as to control the thread with a light pressure, but not hold it with sufficient strength to cause the take-up lever to draw thread through the tension discs, after which the parts are still further retracted to the position shown in **Fig. 25**, in which position they remain until moved forward for the succeeding cutting operation.

The knives must be kept sharp, the teeth in the knife holder pinion and the rack properly meshed together and the knife holder bracket firmly secured in place; at the final puncture of the needle before stopping, the knives should have moved forward and stopped in such position that a gentle pressure of the knife bar will cause the needle thread knife to clear the needle 1/32 inch to 1/16 inch, so that the needle will not strike the knife in the last puncture.

This position is secured by means of adjustment provided for the knife bar; this bar is in two pieces which may be separated further or be brought closer together, thus making the bar shorter or longer. When the position is correct, the time of the knives can be adjusted as follows: the shuttle thread knife must meet the heel of the shuttle at the needle hole during the stitch preceding the last one of the group, and engage the thread where the shuttle has spread it most.

TO REGULATE THE TENSION ON THE STOP CAM INTERLOCKING ROD CASE SPRING

The tension on the stop cam interlocking rod case spring **J**, **Fig. 2** should be sufficiently strong to move the interlocking rod into engagement with the notch in the stop cam when the interlocking rod case is released by the trip lever. The tension is regulated by loosening the lock nut and turning the adjusting screw **H**, **Fig. 2** inwardly to increase the tension, or outwardly to decrease the tension. When the required tension is obtained, securely tighten the lock nut.

SINGER Needles should be used
in SINGER Machines.
These Needles and their Containers
are marked with the
Company's Trade Mark "SIMANCO.*" 1

Needles in Containers marked
"FOR SINGER MACHINES"
are NOT **SINGER** made needles. 2